

ACROW

Beam - S12

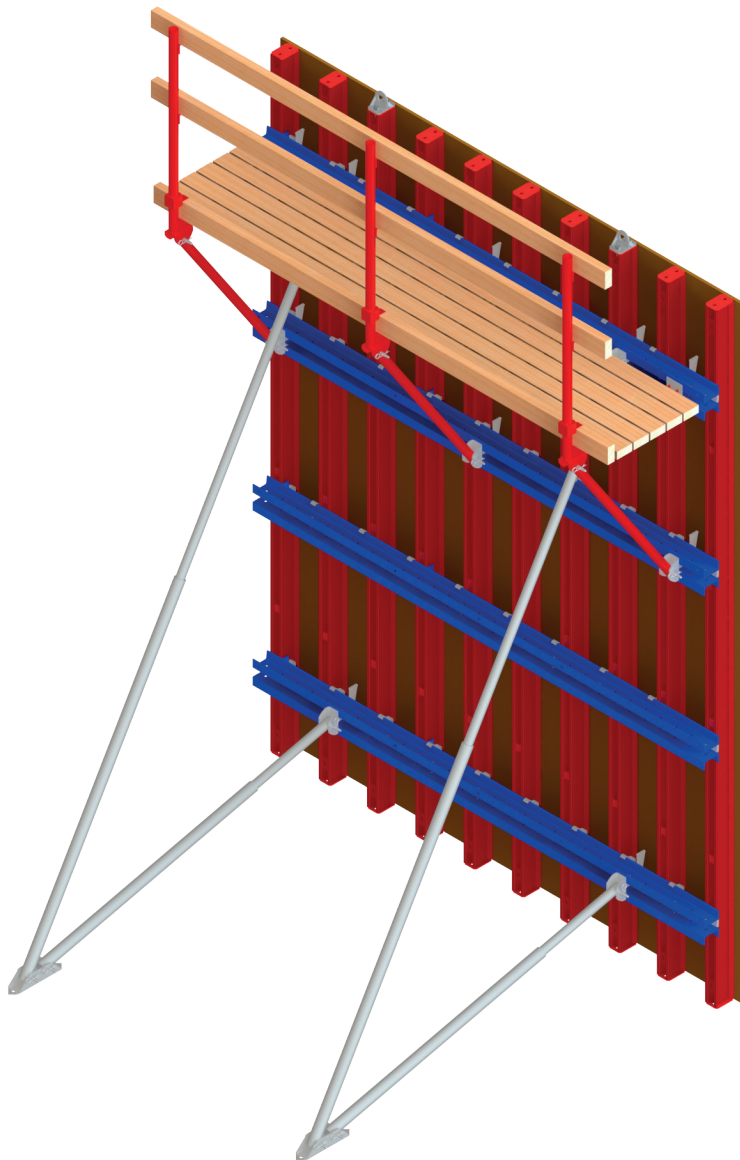

1. **Product Description**
2. **Concept of The System**
3. **Advantages**
4. **System Application**
5. **System components for columns**
6. **Components and accessories**

1- Product Description

Acrow Beam S12 is a new alternative to the standard H20 timber beam. It is used for both walls and columns formworks. It has a higher load capacity (especially in shear resistance) which saves money in soldiers & tie-rods (in walls). It is also more durable than H20 timber girders thus has a longer life. Moreover, elements dismantling are done as easily as system erection. The main Beam S12 advantage is that it providing both high adaptation and easy re- assembling when the geometry of the structure are changing. In addition, this system is one of the most economical compared to the steel frame formwork panel system, where it comes to both complicated designs and numerous non-standard components and height limitations.

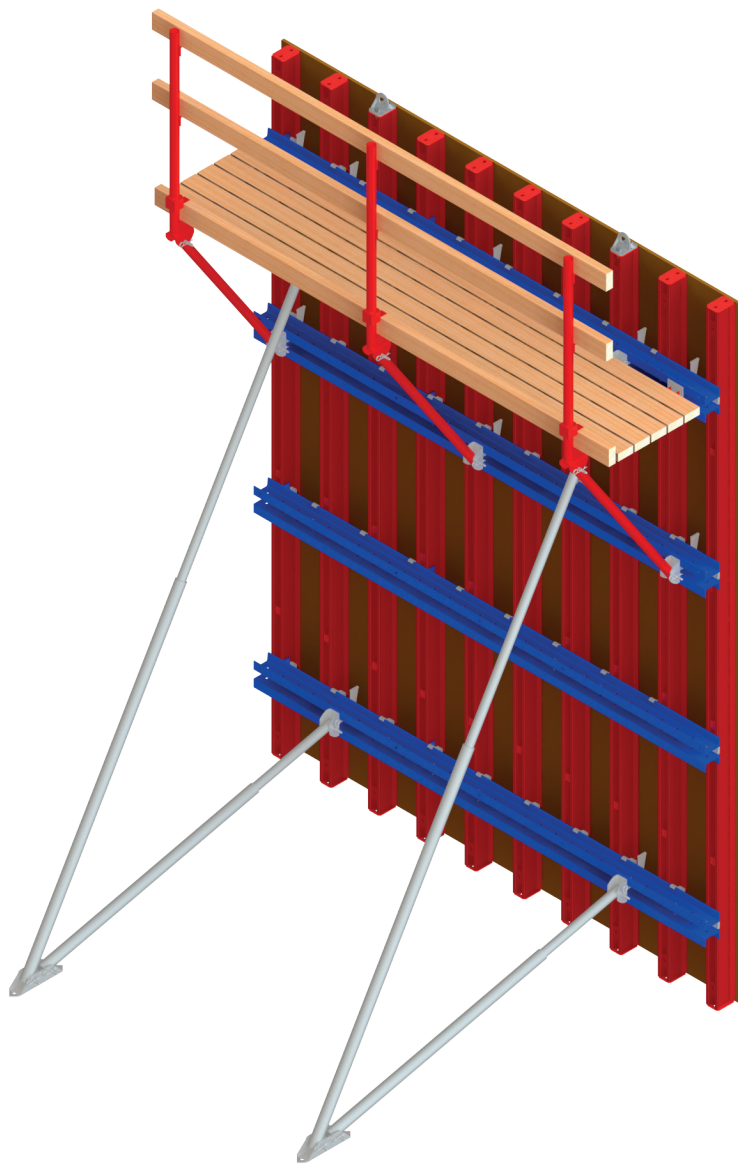

2- Concept of The System

The main feature of this system is its flexibility. This system offers to assemble the Panels depending on the:

Shape: This system enables to assemble customized Panels with the needed dimensions, always with standard components.

Size: Panels can be up to 36m².

Formwork Sheeting: several types of plywood or Acrow Board can be used depending on the desired number of repetitions and the concrete finish. Acrow the optimum usage experience.

(Please check Acrow Board User Manual)

Concrete pressure: the spacing between Acrow Beam S12 and soldiers can be adjusted, depending on the designed fresh concrete pressure.

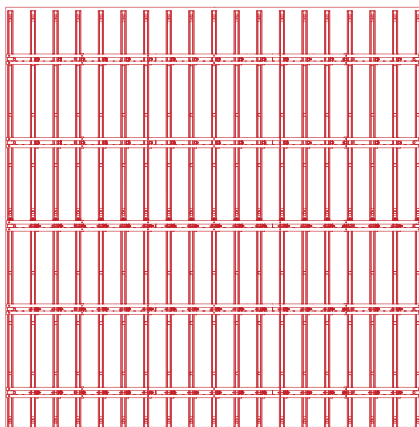

6x6m panel

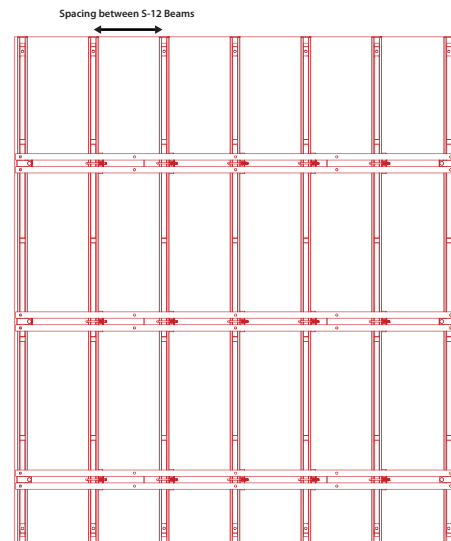

Configuration of a Panel for
a 30 kN/m² concrete pressure

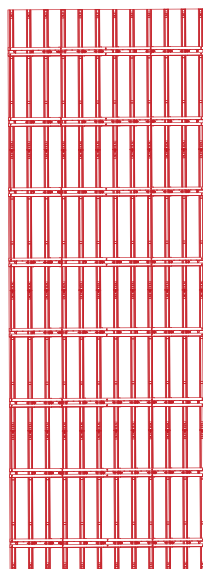

3.6x10m panel

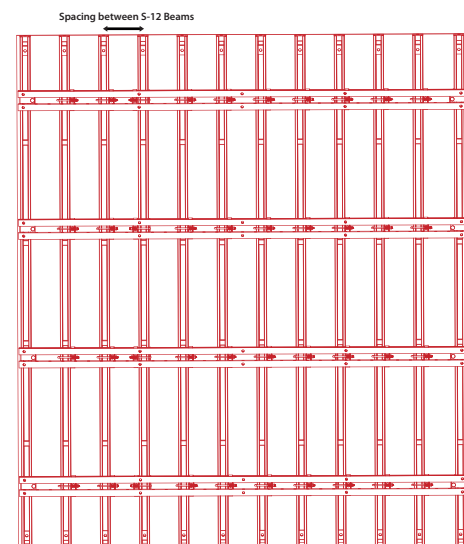

Configuration of a Panel for
a 70 kN/m² concrete pressure

3- Advantages

- High-load capacity for walls & slabs.
- Bended and welded edges to increase life and prevent twists and distortions.
- End plates to prevent deformations at ends, and to allow connecting 2 beams together as an extension to get longer lengths.
- Size: Comes in different sizes starting from 2m to 4m in 0.5m increments. Built-in timber that allow fixation of plywood in case of walls formwork or working as secondary girders in slabs formwork.
- Standard accessories to allow full functionality with different systems.
- Available safety accessories.

4- System Application

- 1 Straight Connections
- 1-1 Joint Between Panels (Without Filler)
- 1-2 Joint Between Panels (With Filler)
- 2 Corner Connections
- 2-1 90° Corners
- 2-2 Acute & obtuse-angled corners
- 3 T-Corners
- 4 Pilasters
- 5 End Connection
- 6 Round Connection
- 7 Columns
- 8 Lifting of Panel
- 9 Access Bracket

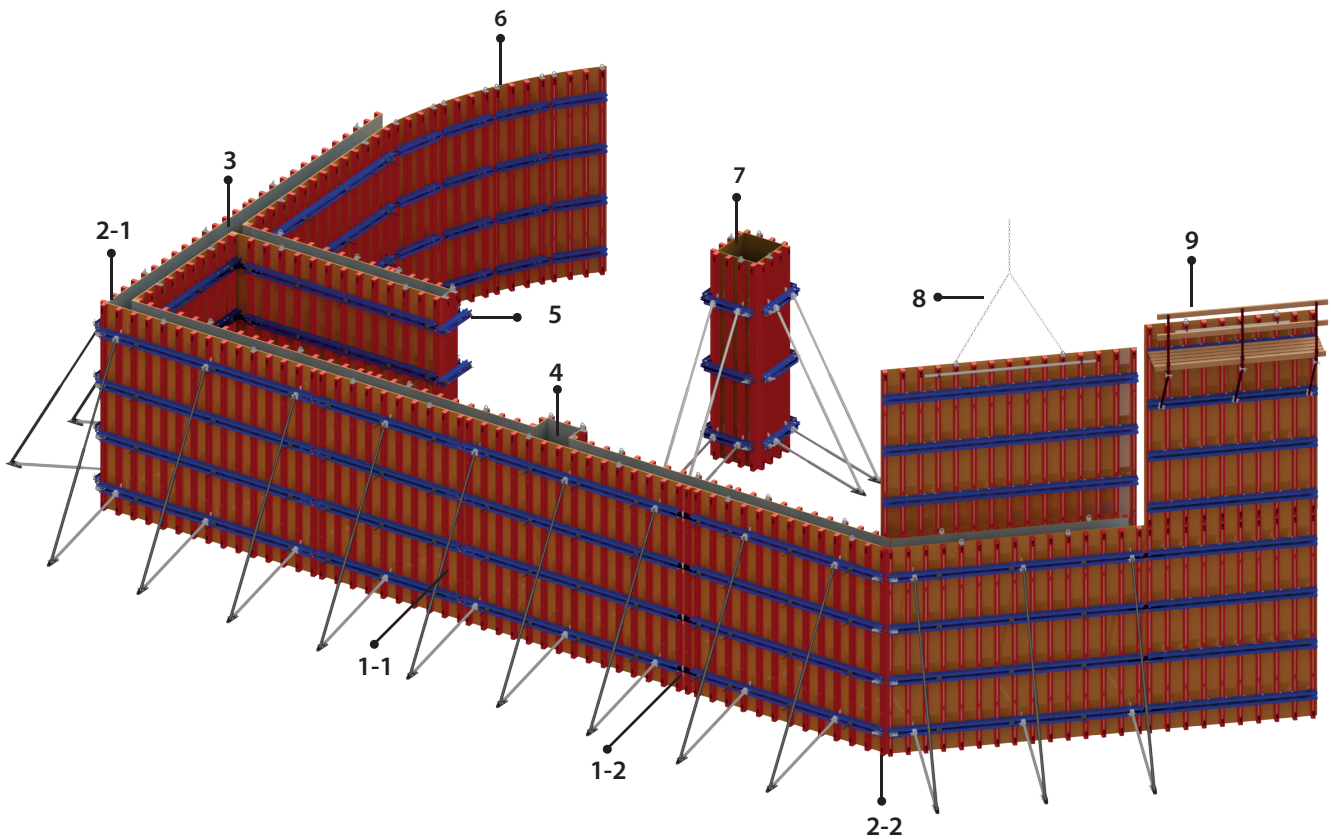

5- System components for columns

By using the same components of the Acrow Beam and soldier wall formwork system, a column formwork can be easily assembled.

- 1- Acrow Beam
- 2- Plywood
- 3- Corner Splice
- 4- Shore Connector
- 5- Small Wedge
- 6- Soldier
- 7- Universal corner angel tie
- 8- Tie Rod
- 9- Double Base Plate
- 10- Push pull prop

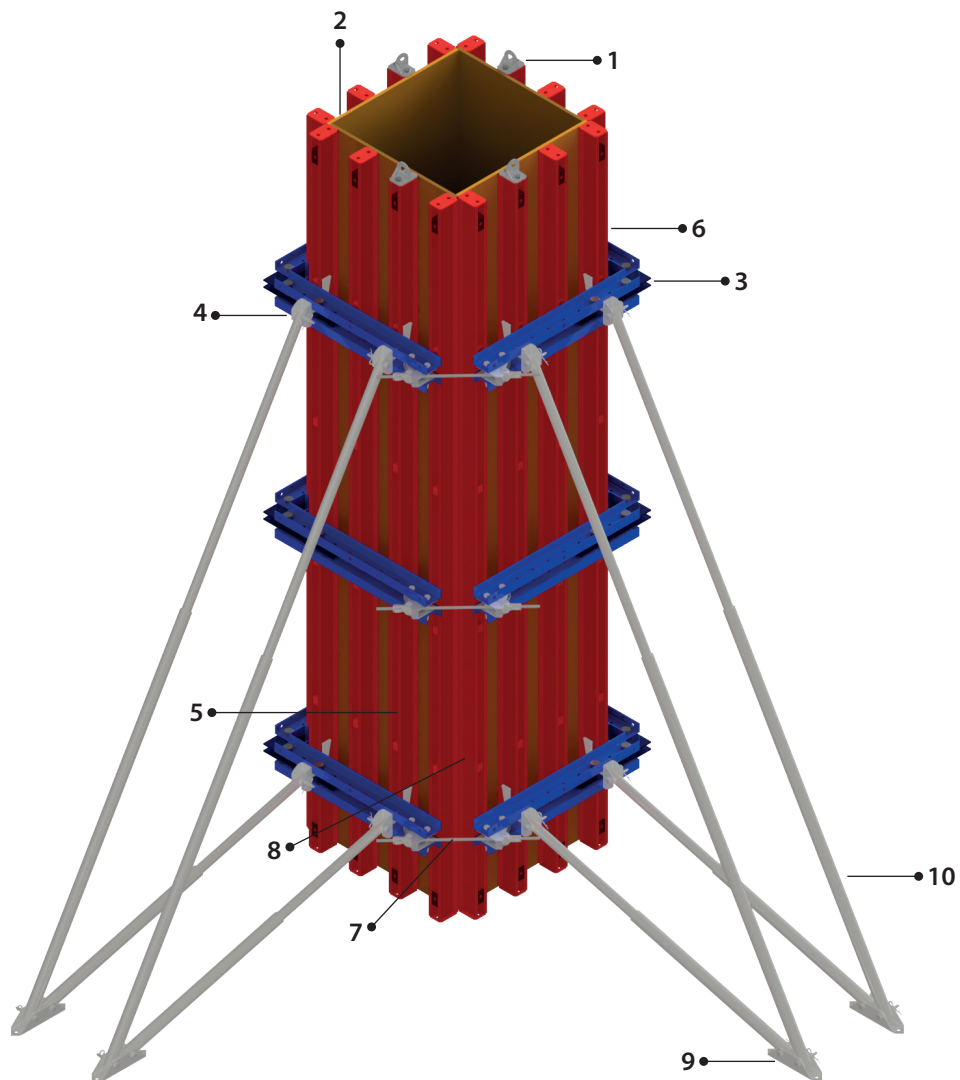

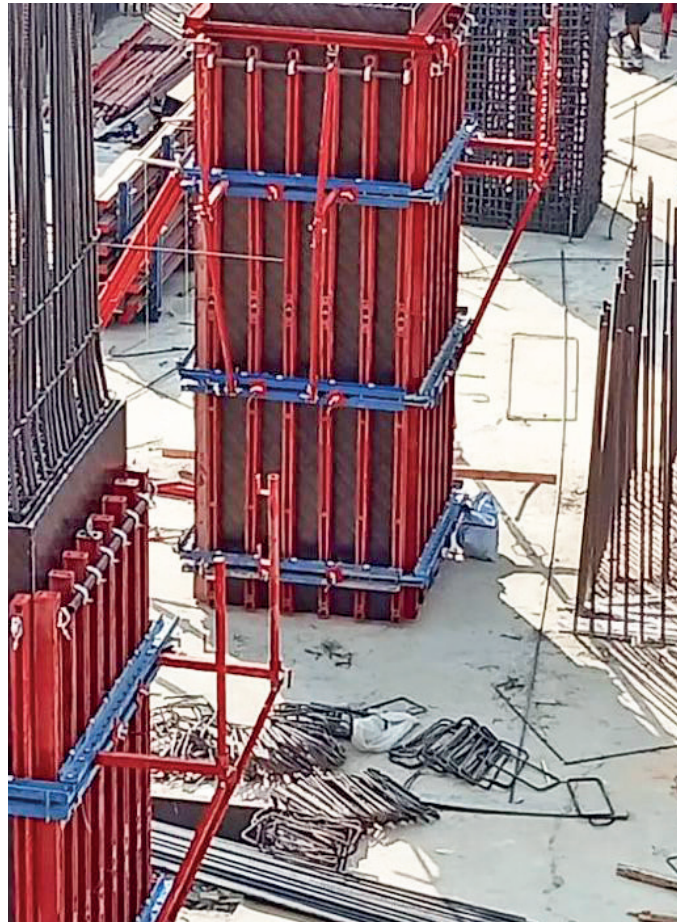
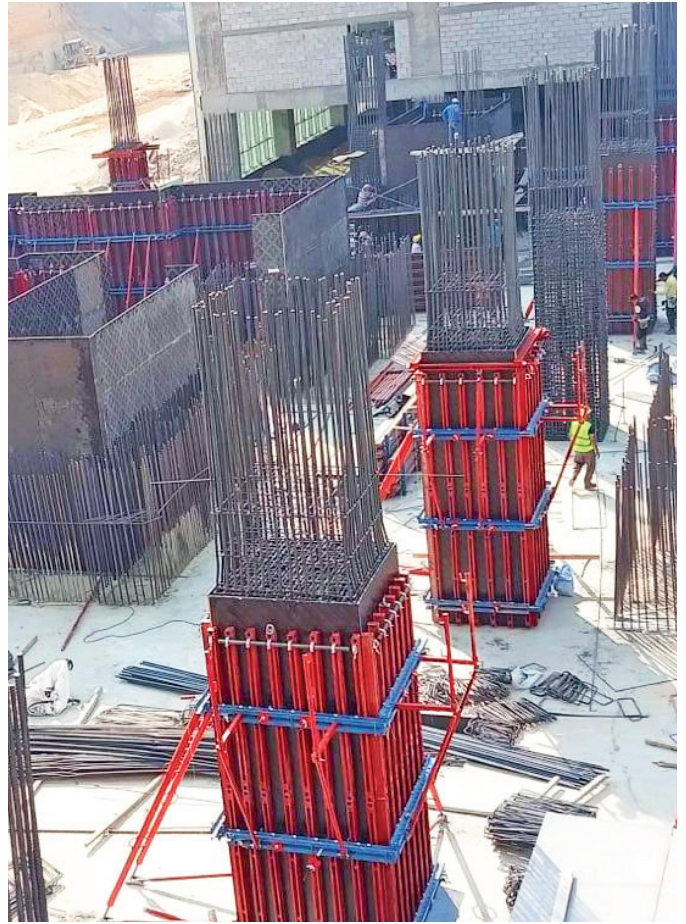



6- Components and accessories

1- Steel waler splice

Using Acrow splice, the two panels can be easily and fastly connected together. In addition, they will be connected using the same waler splice with Rivet Pin eliminating the need for a wrench and bolting fixation time.

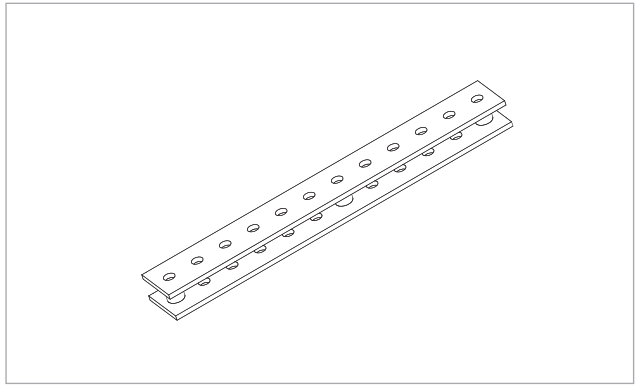

2- Scaffolding Tube and Half Couplers

It is placed near the top of the Panel to absorb the horizontal forces when lifting.

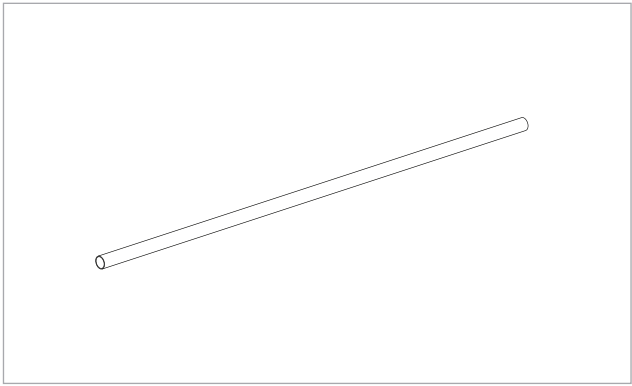

3- Lifting Hook

It makes possible to lift the Panels. Each Panel will have 2 crane splice lifting hooks.

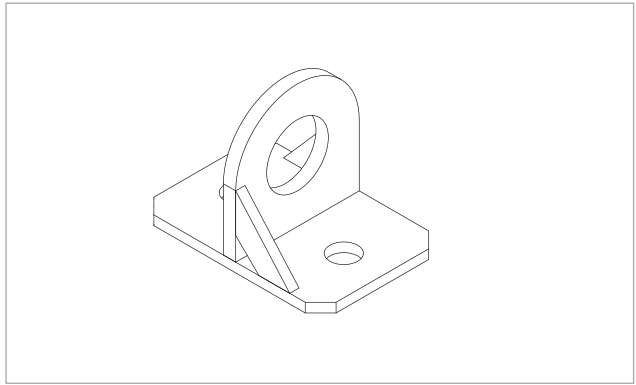

4- Corner Connector (Corner Splice)

It connects 2 Soldiers perpendicular to each other. It will be used to solve:

- 90° corners.
- Elevator cores.
- Columns.
- Pilasters.

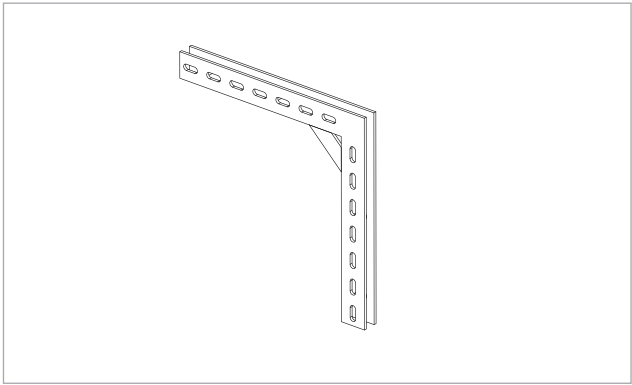

5- Plywood (18 mm)/Acrow Board

It is the Panel surface in contact with the concrete; it can be used more or fewer times.

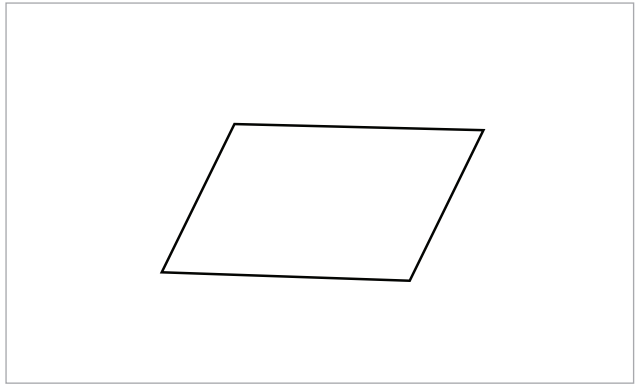

6- Pivot splice

It joins 2 Soldiers when the inside angle between them doesn't form a 90° angle.

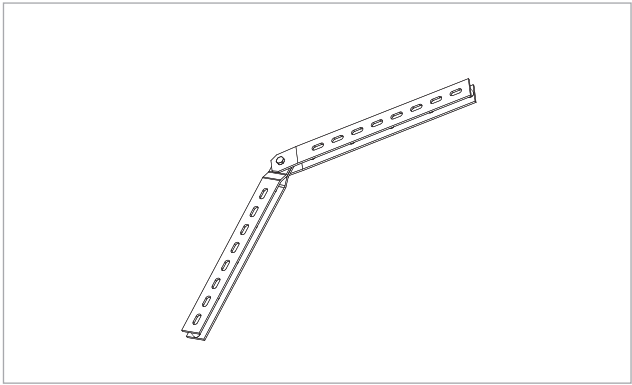

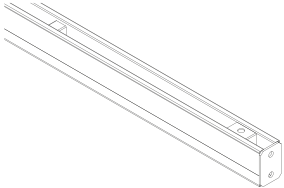
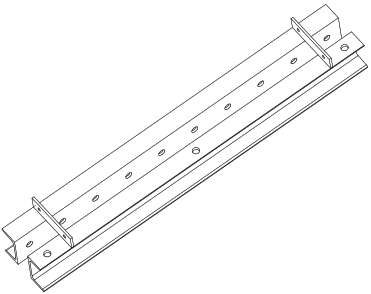
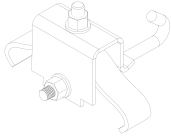
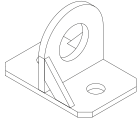
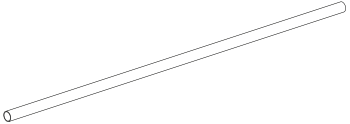
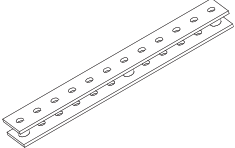
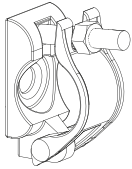
Item	Description	Code No.	Weight (kg)
	Acrow Beam S12 , L=1.80m	6221177140618	14.40
	Acrow Beam S12 , L=2.00m	6221177132101	16.00
	Acrow Beam S12 , L=2.50m	6221177127862	20.00
	Acrow Beam S12 , L=3.00m	6221177127848	24.00
	Acrow Beam S12 , L=3.50 m	6221177134440	28.00
	Acrow Beam S12 , L=4.00m	6221177131937	32.00
	Acrow Beam S12 , L=4.50m	6221177131944	36.00
	Soldier U100 ,L=0.50 m	6221177115050	11.80
	Soldier U100 ,L=0.75 m	6221177115074	16.10
	Soldier U100 ,L=1.00 m	6221177115081	21.40
	Soldier U100 ,L=1.25 m	6221177115098	26.40
	Soldier U100 ,L=1.50 m	6221177115104	31.40
	Soldier U100 ,L=1.75 m	6221177115111	36.60
	Soldier U100 ,L=2.00 m	6221177115128	42.20
	Soldier U100 ,L=2.25 m	6221177115135	47.60
	Soldier U100 ,L=2.50 m	6221177115142	52.00
	Soldier U100 ,L=2.75 m	6221177115159	58.90
	Soldier U100 ,L=3.00 m	6221177115166	63.60
	Soldier U100 ,L=3.25 m	6221177115173	70.80
	Soldier U100 ,L=3.50 m	6221177115180	73.50
	Soldier U100 ,L=3.75 m	6221177115197	78.00
	Soldier U100 ,L=4.00 m	6221177115203	86.20
	Soldier U100 ,L=4.50 m	6221177115210	96.70
	Soldier U100 ,L=5.00 m	6221177115227	104.00
Soldier U100 ,L=5.50 m	6221177115234	114.70	
Soldier U100 ,L=6.00 m	6221177115241	126.50	
	Soldier-S12 connection-S	6221177141684	0.85
	Soldier-S12 End Connection	6221177135768	0.75
	S12 - Curved Splice Connection	6221177137519	0.75
	Lifting (Eye) Hook for Acrow Beam S12	6221177134082	0.80
	Bolt M16 × 40 mm (8.8)	2012060062780	0.10
	Scaffolding Tube L=2.00 m (Painted)	6221177017484	5.70
	Scaffolding Tube L=2.50 m (Painted)	6221177017491	7.13
	Scaffolding Tube L=3.00 m (Painted)	6221177017507	8.55
	Scaffolding Tube L=3.50 m (Painted)	6221177017514	9.98
	Scaffolding Tube L=4.00 m (Painted)	6221177017521	11.40
	Scaffolding Tube L=4.50 m (Painted)	6221177017538	12.83
	Scaffolding Tube L=5.00 m (Painted)	6221177017545	14.25
	Scaffolding Tube L=5.50 m (Painted)	6221177064495	15.68
	Scaffolding Tube L=6.00 m (Painted)	6221177017552	17.10
	Splice 60cm (double)	6221177022242	6.50
	Splice 90cm (double)	6221177022266	9.50
	Splice 90cm (double)(S&H)	6221177147655	6.50
	Forged Half Swivel Coupler (1.5") (Type I)	6221177089689	0.80
	Bolt M16 × 30 mm (8.8)	2012060063986	0.10
	Nut M16 (8.8)	2012180029632	0.033

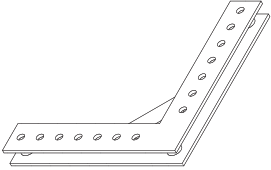
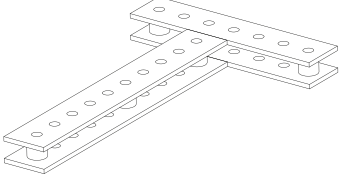
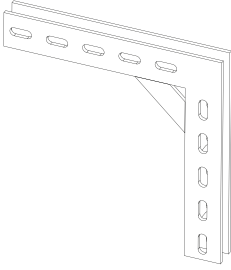
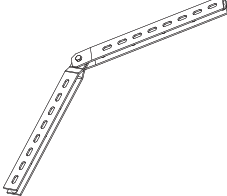
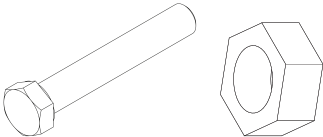
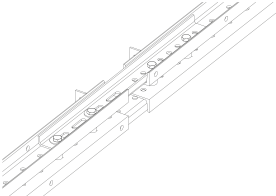
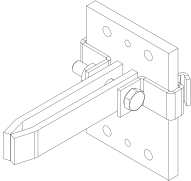
Item	Description	Code No.	Weight (kg)
	Corner Splice 60x30cm (for soldier) Corner Splice 45x45cm (for soldier) Corner Splice 60x45cm (for soldier) Corner Splice 60x60cm (for soldier)	6221177032623 6221177022112 6221177022129 6221177022136	8.80 8.75 10.35 11.90
	T-Splice	6221177022280	9.85
	Corner Splice 60x60 cm (Slotted) Corner Splice 45x45 cm (Slotted)	6221177147389 6221177147396	11.80 8.70
	Pivot Splice 30x30cm (Slotted) Pivot Splice 45x45cm (Slotted) Pivot Splice 60x60cm (Slotted) Pivot Splice 75x75cm (Slotted)	6221177147341 6221177147358 6221177147365 6221177147372	6.50 9.50 12.50 15.50
	Bolt M16 x 100 mm Nut M16	2012090028565 2012210029779	0.20 0.033
	Unit Of Channel Splice 90cm	6221177142889	15.00
	Compression Plate for Acrow Beam S12 Small Wedge (5cm)	6221177????? 6221177082918	1.60 0.43

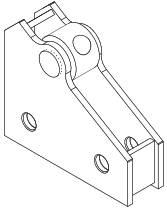
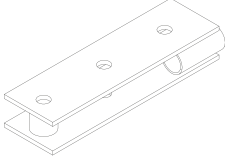
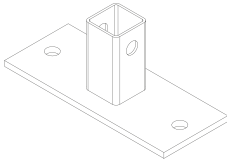
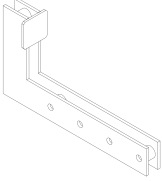
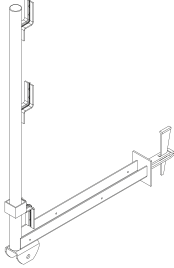
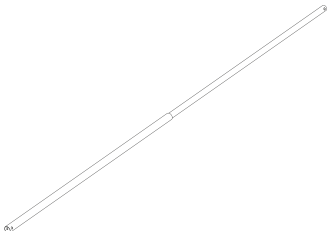
Item	Description	Code No.	Weight (kg)
	Universal Corner Angle Tie Holes (new)	6221177026042	2.40
	Stop-End Splice	6221177028008	2.35
	Base Plate For Soldier (381-115)	6221177129705	2.30
	Assembling Bracket (For H 20 & S 12)	6221177144234	8.50
	Access Bracket-L- (Hr-VI) For Soldier (8-10)cm Access Bracket-L-For HL.Soldier][10 shore connector for Hz. Soldier][10 (U-lug) Small Wedge (5cm) Diagonal tube Lv= ??? Rivet Pin 17 mm, L=12.5 cm (Type I) Spring Clip (medium)	6221177133641 6221177102357 6221177086824 6221177082918 6221177012304 6221177087289	8.00 10.20 1.45 0.43 0.25 0.03
	Tilt Up Shore X0 (Galv.) Tilt Up Shore X1 (Galv.) Tilt Up Shore X2 (Galv.) Tilt Up Shore X3 (Galv.) Tilt Up Shore X4 (Galv.)	6221177112424 6221177112431 6221177112448 6221177112455 6221177112462	12.00 18.60 19.70 22.40 26.70

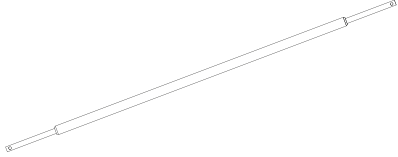
Item	Description	Code No.	Weight (kg)
	Push Pull PPS132	6221177014261	13.70
	Push Pull PPS162	6221177014285	14.85
	Push Pull PPS202	6221177014308	16.10
	Push Pull PPS252	6221177014315	18.00
	Push Pull PPS302	6221177014322	20.00
	Push Pull PPS352	6221177014339	24.00
	Push Pull PPH164	6221177014032	24.75
	Push Pull PPH204	6221177014056	27.00
	Push Pull PPH206	6221177014070	29.50
	Push Pull PPH254	6221177014094	30.40
	Push Pull PPH304	6221177014117	33.75
	Push Pull PPH354	6221177014131	37.00
	Push Pull PPH404	6221177014155	40.50
	Push Pull PPH454	6221177014162	54.00
	Push Pull PPH502	6221177014186	47.10
	Push Pull PPH552	6221177014209	50.50
	Push Pull PPH602	6221177014223	74.00
	Push Pull PPH652	6221177014247	77.50
	Push-Pull Prop MPP1 (1.00:1.60) m	6221177163525	12.30
	Push-Pull Prop MPP2 (1.60:2.30) m	6221177163532	19.30
	Push-Pull Prop MPP3 (2.00:3.25) m	6221177163549	24.30
Push-Pull Prop MPP4 (2.65:4.65) m	6221177163556	34.10	
Push-Pull Prop MPP5 (4.45:6.75) m	6221177163563	63.40	
Push-Pull Prop MPP6 (6.45:10.00) m	6221177163570	115.75	

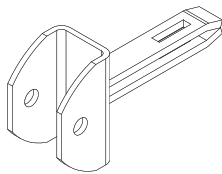

shore connector for Hz. Soldier][10 (U-lug)
Shore Connector For Acrow Beam S12

6221177086824
6221177167547

1.45
2.00



Small Wedge (5cm)

6221177082918

0.43

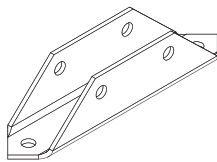

Double Base Plate

6221177000813

2.40

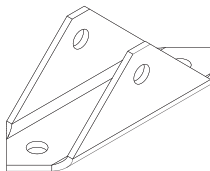

Single Base Plate

6221177000882

1.45





Rivet Pin 17 mm, L=12.5 cm (Type I)

6221177012304

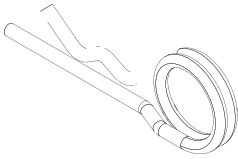
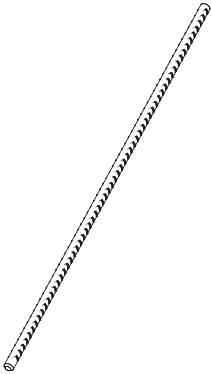
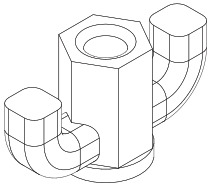
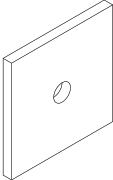
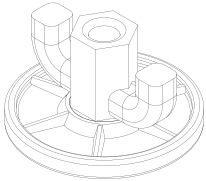
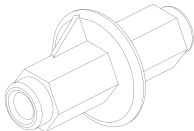
0.25

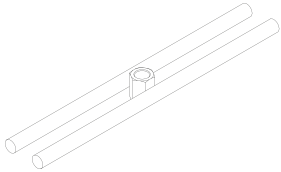
Item	Description	Code No.	Weight (kg)
	Spring Clip (medium)	6221177087289	0.03
	Tie Rod 15mm DW Type (G) L=0.48m Tie Rod 15mm DW Type (G) L=0.57m Tie Rod 15mm DW Type (G) L=0.70m Tie Rod 15mm DW Type (G) L=0.82m Tie Rod 15mm DW Type (G) L=0.95m Tie Rod 15mm DW Type (G) L=1.15m Tie Rod 15mm DW Type (G) L=1.45m Tie Rod 15mm DW Type (G) L=1.68m Tie Rod 15mm DW Type (G) L=1.90m Tie Rod 15mm DW Type (G) L=2.17m Tie Rod 15mm DW Type (G) L=2.42m Tie Rod 15mm DW Type (G) L=2.90m Tie Rod 15mm DW Type (G) L=3.38m Tie Rod 15mm DW Type (G) L=3.90m Tie Rod 15mm DW Type (G) L=4.35m Tie Rod 15mm DW Type (G) L=4.85m Tie Rod 15mm DW Type (G) L=5.80m	6221177153366 6221177153168 6221177137496 6221177153199 6221177152833 6221177130947 6221177099046 6221177159979 6221177141226 6221177159986 6221177153243 6221177107512 6221177153267 6221177153281 6221177153304 6221177153328 6221177153816	0.72 0.86 1.05 1.23 1.43 1.73 2.18 2.52 2.85 3.26 3.63 4.35 5.07 5.78 6.53 7.28 8.70
	Forged Wing Nut 15 mm DVD (Type I)	6221177011314	0.35
	Steel Washer	6221177027513	1.10
	Wing Nut Pivot Plate 15mm DVD	6221177042745	1.55
	Water Barrier (flange type)	6221177053574	0.56
	Reducer for Water Barrier	6221177039219	0.004

Item	Description	Code No.	Weight (kg)
	Hex. Nut Dvd with Welded Bars	6221177136352	1.25
	Corner Filler Panel L-shape , H=1.0m Corner Filler Panel L-shape , H=2.0m Corner Filler Panel L-shape , H=3.0m	6221177006624 6221177006631 6221177006648	12.80 26.50 37.00
	Corner Filler Panel Ladder-shape , H=1.0m Corner Filler Panel Ladder-shape , H=2.0m Corner Filler Panel Ladder-shape , H=3.0m	6221177006594 6221177006600 6221177006617	9.30 18.00 26.35

20 OFFICE

AFRICA

EGYPT

Head Quarter

Factory: Wady Houf, Helwan

Tel.: [+202] 23690 616 / 23690 739

[+202] 23695 700 / 23699 976

Fax: [+202] 23695 260

E-mail: info@acrow.co

Alexandria Branch

27 Dr. mahmoud Daoud st.

Tel.: [+203] 4200 289

E-mail: acrowalex@acrow.co

MOROCCO

221 BVD Zerktoni , 3ème et 4ème

etage - B.N. 06/08, Casablanca

20100, Morocco

Tel. : [+212] 522 945 912

Mob. : [+212] 660 675 640

E-mail: acrowmorocco@acrow.co

ALGERIA

Siege Social, cité des travailleurs lot. 09

groupe 02 Dar El beida, Algiers

Tel.: +213 (0) 23 74 74 37

Tel.: +213 (0) 23 74 74 35

Fax: +213 (0) 23 74 74 37

E-mail: acrow-dz@acrow.co

NIGERIA

Block D, Plot 23, Water Corporation
drive, VI, Lagos.

Tel. : [+234] 818 0000 295

Mob. : [+234] 6061 7290 99

Email : acrownigeria@acrow.co

KENYA

Nairobi

Kiungani Rd, off Mombasa Rd,

Nairobi, Kenya

Tel. : [+254] 772324535

E-mail: acrowkenya@acrow.co

TANZANIA

Dar EsSalam

Oyster Bay Masaki, Dar EsSalam

Tel. : [+255] 768 696 314

E-mail: acrowtanzania@acrow.co

14 BRANCH

ASIA

KSA

Riyadh Office

Office No. 13A- Sultan Business Building

- Almaathar Ash shamali district - Sultan

Ben Abdulaziz Street - Riyadh

Tel. : [+966] 11 216 0504

Fax : [+966] 11 216 0503

Mob. : [+966] 55 001 2693

E-mail: acrowriyadh@acrow.co

Jeddah Office

Office No. 15 - 4th Floor - Zahid

Building - Alsalamah district - Mohamed

Ibrahim Masoud Street - Jeddah

Tel. : [+966] 12 691 7941

Fax : [+966] 12 275 1037

Mob. : [+966] 50 001 3206

E-mail: acrowjeddah@acrow.co

Dammam Office

Office 2, Alsalam Building, Madinat

Alummal Dist., King Fahd Road

Tel. : [+966] 13 805 4151

Fax : [+966] 11 216 0503

Mob. : [+966] 55 468 7057

E-mail: dammam@acrow.co

Madinah Al Munawwarah

Office 6, First Floor, Ghos Building, In

Front Of Saudi Post, Sultanah Street,

Almadinah

Tel. : [+966] 11 216 0504

Fax : [+966] 11 216 0503

Mob. : [+966] 55 775 8197

E-mail: almadinah@acrow.co

Tabuk City

Al Muruj District

Prince Mamdouh Bin Abdul Aziz Street

Building Name : Tabuk Business Center

Building No.2786

PO.Box : 47312

Second Floor , Office No.203

Tel. : [+966] 11 216 0504

Fax : [+966] 11 216 0503

Mob. : [+966] 55 001 2693

E-mail: acrowriyadh@acrow.co

UAE

Dubai

Office 1002, The Onyx Tower 2- The
greens - Dubai.

Tel. : [+971] 43439498

Fax : [+971] 43439598

Mob. : [+971] 528228811

E-mail: acrowgulf@acrow.co

Abu Dhabi

Office 816, Al Junaibi Tower, Al Muroor
Road - Abu Dhabi.

Mob. : [+971] 588113383

E-mail: acrowad@acrow.co



EUROPE

ROMANIA

Acrow SRL

Strada Intrarea Panduri 4, Rudeni 077046,
Romania

Mob. : [+40] 721 297 342

E-mail: acrow.romania@acrow.co

KUWAIT

Al Aridiyah , Block 2 , Building 92,
Kuwait Khalid Ali Al Kharafi &
Bros.Co.W.LL

Tel.: [+965] 22083000 – Ext [240]

Fax: [+965] 22083001

E-mail: acrowkuwait@acrow.co

BAHRAIN

Acrow Bahrain Co. W.L.L

Office 1718, building 1260, Road 2421
Block 324 , Juffair, Manama , Kingdom of Bahrain

Mob. : [+973] 35 176 860

E-mail: acrowbahrain@acrow.co

QATAR

Acrow Qatar

Salwa Road, Red Tag building,
1st floor, Doha

P.O. Box No.: 15104

Tel.: [+974] 44582357

Fax: [+974] 44582376

E-mail: acrowqatar@acrow.co

OMAN

Acrow LLC

Office 23, Bin Hayl 2 Building , Bawshar
St ,Muscat , Sultanate of Oman

Tel. : [+968] 24 112 791

Mob. : [+968] 92 543 734

E-mail: acrowmuscat@acrow.co

JORDAN

Jordan - Amman - Al Jandawil - Hosni
Subar Str - Building no 05 - Third Floor

Mob. : [+962] 797 603 936

E-mail: acrow.jordan@acrow.co



Contact Us

Head Office

Factory: Wady Houf, Helwan

Tel: (+202) 23254529 / 23254528
(+202) 23254501 / 23254531

Fax: (+202) 23671 347

E-mail: info@acrow.co

