



ACROW
Formwork Technology



Acrow Big Steel Panel

ACROW MISR Provides Full Site Service Based On More Than 35 Years Experience In The Field

ACROW
Formwork Technology

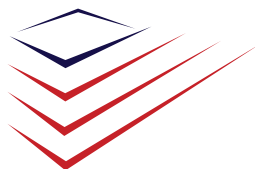

ACROW
Formwork Technology





Contents

Introduction	2
Acrow Big Steel Panel For Bridge Pier Crown	3
Acrow Big Steel Panel With Acrow Climbing System For Column	9
Acrow Big Steel Panel For Column With Special Shape	11
Acrow Big Steel Panel For Tunnel Form	16

Introduction

Being one of the largest formwork and scaffolding companies in Egypt, We are introducing the Big Steel Panels Formwork System.

Advantages of big steel panel:

- It is one of the most economical systems for special applications.
- It can be easily erected, adjusted and dismantled

- It is by made high manufacturing techniques.
- The release agent coating minimizes the concrete adhesion.



Acrow Big Steel Panel For Bridge Pier Crown

Project : Cairo Alex Road Bridge
Location : Egypt

Acrow big steel panel is the most suitable system for bridge pier crown, where special shapes and complicated architecture texture are easily achieved using big steel panel formwork rather than modular systems.

Pier crown height=7.80 width=3.50m



- Steel panel width = 2 m.
- Steel panel Height = 1.5 m.
- Curved steel panel = 1.5 m.
- Face crown width = 3.5 m to 5 m
Height = 3.05 m
- Side crown width = 1.5 m
Height = 3.05 m

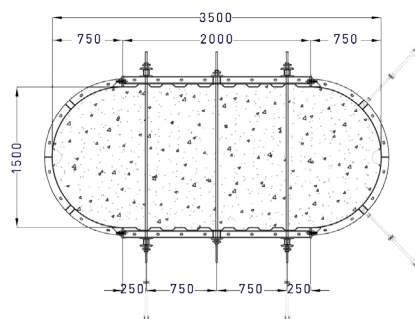

Section(1-1)

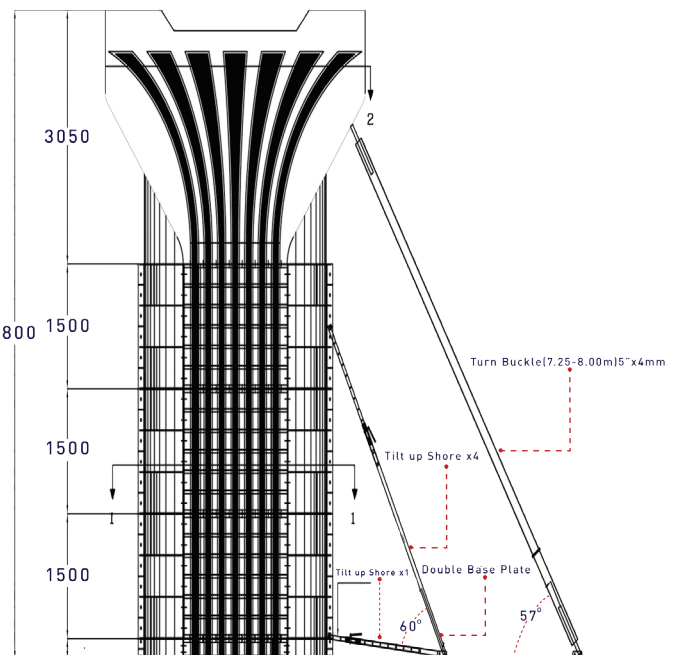

Acrow Big Steel Panel For Bridge Pier Crown



ELEVATION OF PIER

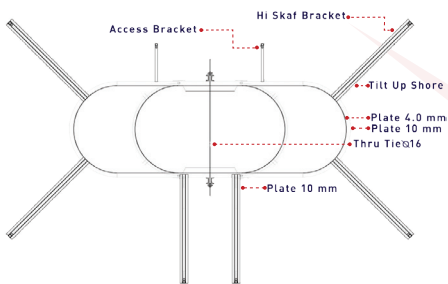

PLAN OF CROWN

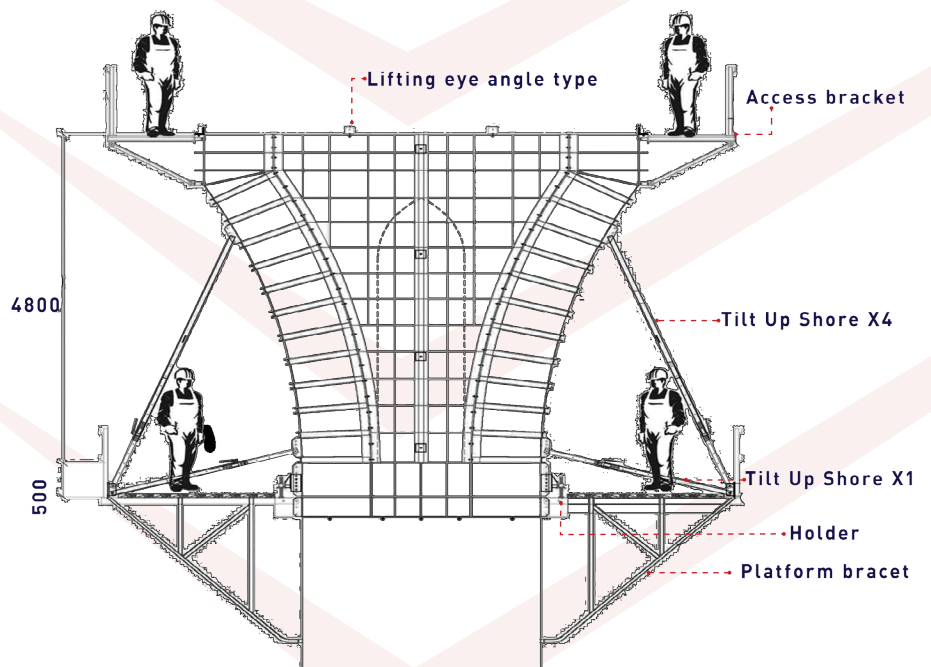
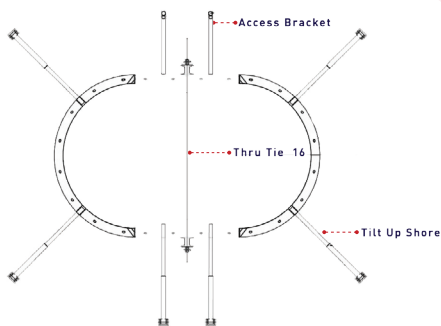

Applications Acrow Big Steel Panel For Bridge Pier Crown



Applications Acrow Big Steel Panel For Bridge Pier Crown

Qatar



Applications Acrow Big Steel Panel For Bridge Pier Crown

Qatar



Acrow Big Steel Panel For Bridge Pier Crown

Project : Met Ghamr bridge
Location : Met Ghamr - Egypt



Acrow Big Steel Panel With Acrow Climbing System For Column

Project : Riyadh ring road north
(west leg)
Contractor : Shibh El Jezira
Location : Saudi Arabia



Acrow Big Steel Panel With Acrow Climbing System For Column

Project : Riyadh ring road north
(west leg)
Contractor : Shihb El Jezira
Location : Saudi Arabia



Acrow Big Steel Panel For Column With Special Shape

Project : Sewage treatment water tank
 Client : Alгна Alshabia for Electricity & Water
 Contractor : Bavaria
 Location : Libya

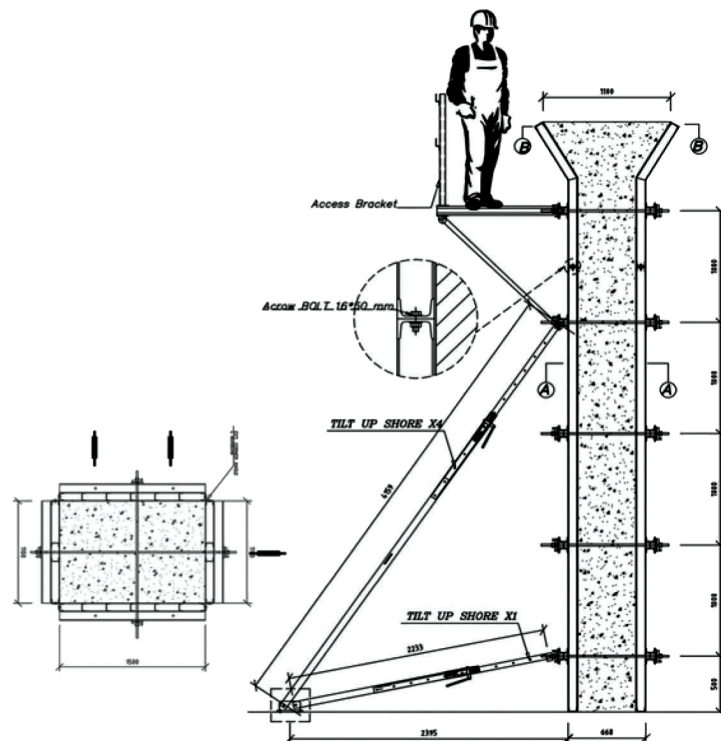

Acrow Big Steel Panel For Column With Special Shape

Project : Sewage treatment
water tank
Client : Algna Alshabia for
Electricity & Water
Contractor : Bavaria
Location : Libya



Acrow Big Steel System With One Level Of W/S Ties (H - 7.40)

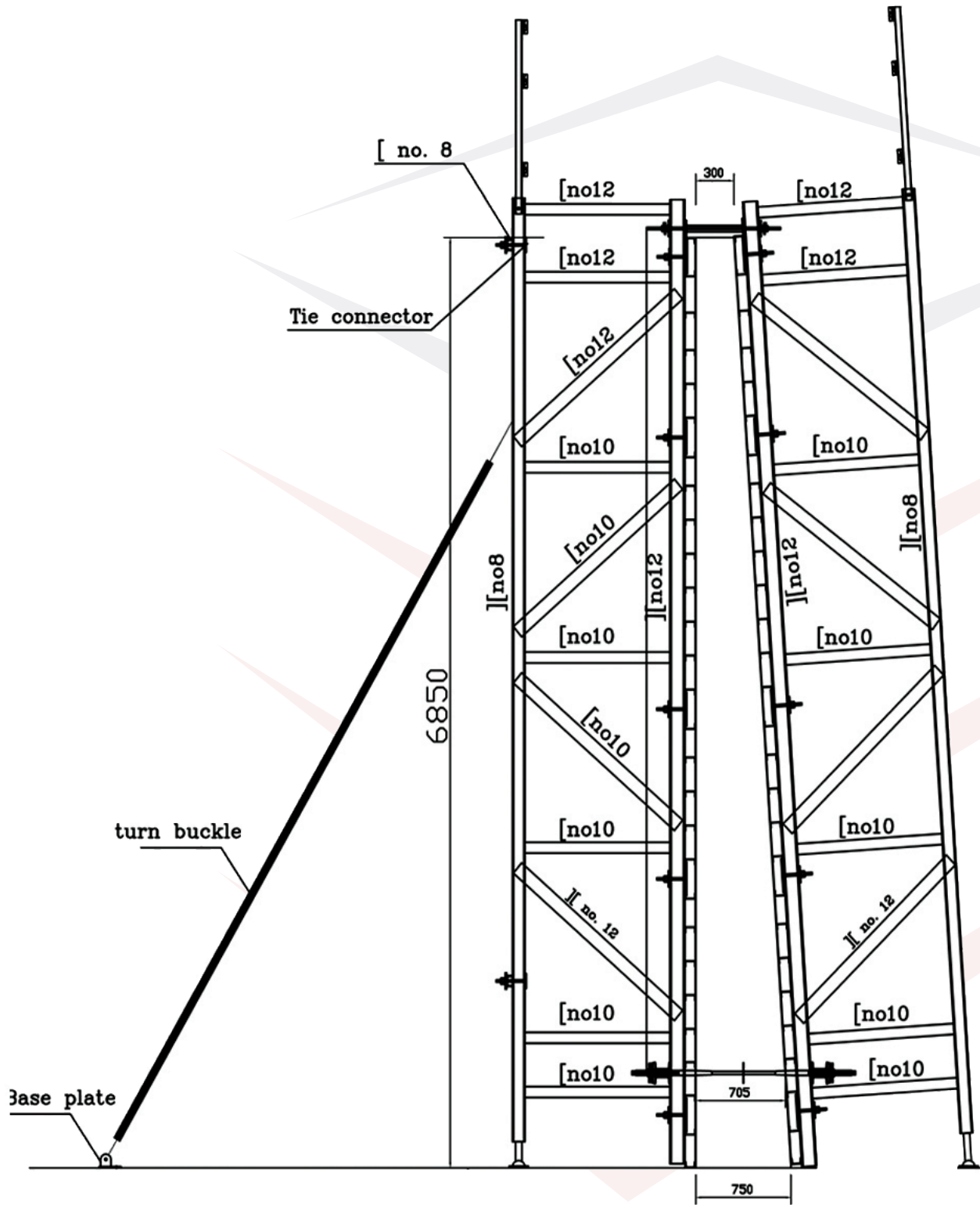

Acrow Big Steel Panel For Column With Special Shape

Project : Azzoure Ground Water Tank
Contractor : arab contractors
(osman a .osman)
Location : Kuwait



Acrow Big Steel For Tunnel Form

All the inside forms move on wheels:

- Acrow steel panel system has been successfully used for monolithic tunnel formwork. The main system advantage is that it enables a one shot

pour for the slab and walls together.

- The inner formwork is equipped by wheels in order to be moved easily form one stage to another.
- The outer formwork can be either

moved by wheel or crane according the surrounding site conditions.

- Acrow misr also designs, forms, assembles, and supplies special tunnel form shapes upon request.

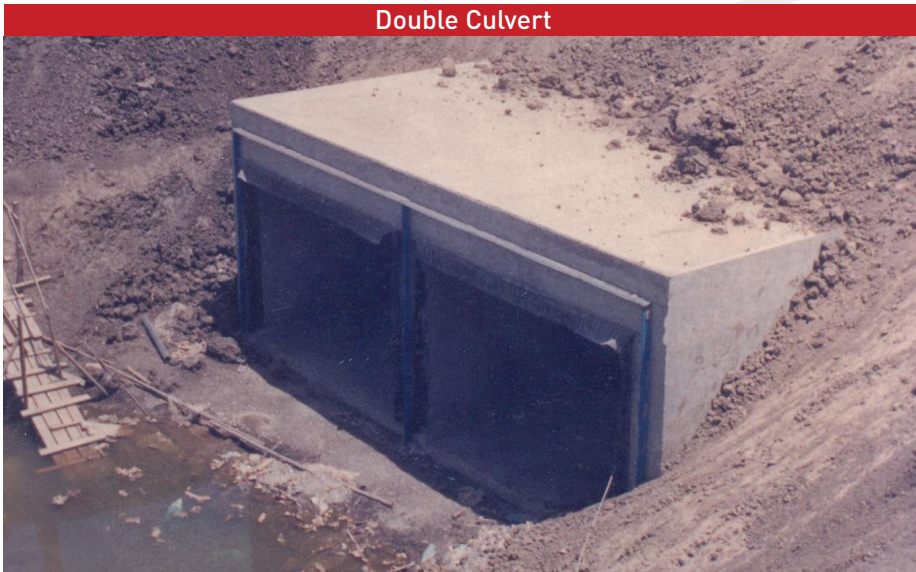

Double Culvert



Single Culvert

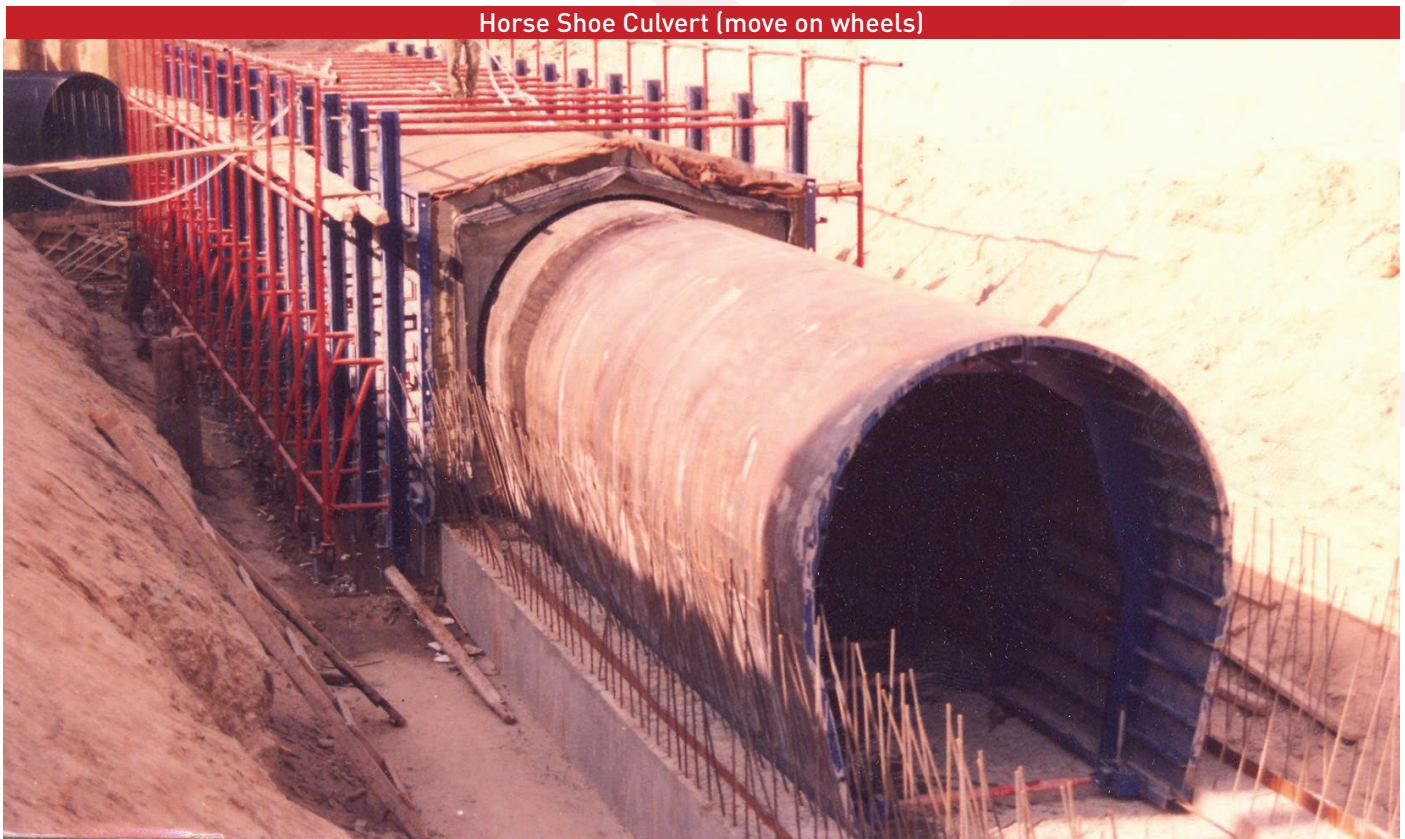

Horse Shoe Culvert (move on wheels)

Acrow Big Steel Panel For Tunnel Form

Advantages of tunnel formwork:

- Easy to use in site
- Monolithic reinforced walling formwork system
- It enables fast track construction
- It proved to be cost effective system
- Transferrable construction technology
- It is reusable system which could be used many times.
- It is characterized by its light weight.
- It is a time effective system which enables fast and speedy tunneling formwork and construction.



ACROW

Formwork Technology



Acrow H20 & solidier

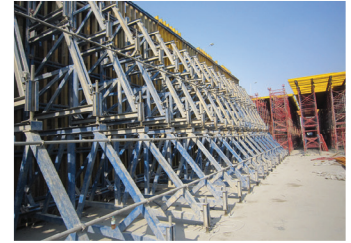

Acrow One shutter solidier



Acrow V.M.C



Acrow Tech-Form



Acrow Cuplock



Acrow Bridge table form



Acrow Circular column



Acrow climbing system



Acrow shorbrace Table form



Acrow Big steel panel



Acrow European prop



Acrow Vari form



Acrow Prop table form



Acrow frame



Acrow early striking system



Acrow Ring lock

www.acrow.co

20 OFFICE

AFRICA

EGYPT

Head Quarter

Factory: Wady Houf, Helwan

Tel.: [+202] 23690 616 / 23690 739

[+202] 23695 700 / 23699 976

Fax: [+202] 23695 260

E-mail: info@acrow.co

Alexandria Branch

27 Dr. mahmoud Daoud st.

Tel.: [+203] 4200 289

E-mail: acrowalex@acrow.co

MOROCCO

221 BVD Zerktoni , 3ème et 4ème

etage - B.N. 06/08, Casablanca

20100, Morocco

Tel. : [+212] 522 945 912

Mob. : [+212] 660 675 640

E-mail: acrowmorocco@acrow.co

ALGERIA

Siege Social, cité des travailleurs lot. 09

groupe 02 Dar El beida, Algiers

Tel.: +213 (0) 23 74 74 37

Tel.: +213 (0) 23 74 74 35

Fax: +213 (0) 23 74 74 37

E-mail: acrow-dz@acrow.co

NIGERIA

Block D, Plot 23, Water Corporation
drive, VI, Lagos.

Tel. : [+234] 818 0000 295

Mob. : [+234] 6061 7290 99

Email : acrownigeria@acrow.co

KENYA

Nairobi

Kiungani Rd, off Mombasa Rd,

Nairobi, Kenya

Tel. : [+254] 772324535

E-mail: acrowkenya@acrow.co

TANZANIA

Dar EsSalam

Oyster Bay Masaki, Dar EsSalam

Tel. : [+255] 768 696 314

E-mail: acrowtanzania@acrow.co

14 BRANCH

ASIA

KSA

Riyadh Office

Office No. 13A- Sultan Business Building

- Almaathar Ash shamali district - Sultan

Ben Abdulaziz Street - Riyadh

Tel. : [+966] 11 216 0504

Fax : [+966] 11 216 0503

Mob. : [+966] 55 001 2693

E-mail: acrowriyadh@acrow.co

Jeddah Office

Office No. 15 - 4th Floor - Zahid

Building - Alsalamah district - Mohamed

Ibrahim Masoud Street - Jeddah

Tel. : [+966] 12 691 7941

Fax : [+966] 12 275 1037

Mob. : [+966] 50 001 3206

E-mail: acrowjeddah@acrow.co

Dammam Office

Office 2, Alsalam Building, Madinat

Alummal Dist., King Fahd Road

Tel. : [+966] 13 805 4151

Fax : [+966] 11 216 0503

Mob. : [+966] 55 468 7057

E-mail: dammam@acrow.co

Madinah Al Munawwarah

Office 6, First Floor, Ghos Building, In

Front Of Saudi Post, Sultanah Street,

Almadinah

Tel. : [+966] 11 216 0504

Fax : [+966] 11 216 0503

Mob. : [+966] 55 775 8197

E-mail: almadinah@acrow.co

Tabuk City

Al Muruj District

Prince Mamdouh Bin Abdul Aziz Street

Building Name : Tabuk Business Center

Building No.2786

PO.Box : 47312

Second Floor , Office No.203

Tel. : [+966] 11 216 0504

Fax : [+966] 11 216 0503

Mob. : [+966] 55 001 2693

E-mail: acrowriyadh@acrow.co

UAE

Dubai

Office 1002, The Onyx Tower 2- The
greens - Dubai.

Tel. : [+971] 43439498

Fax : [+971] 43439598

Mob. : [+971] 528228811

E-mail: acrowgulf@acrow.co

Abu Dhabi

Office 816, Al Junaibi Tower, Al Muroor
Road - Abu Dhabi.

Mob. : [+971] 588113383

E-mail: acrowad@acrow.co



EUROPE

ROMANIA

Acrow SRL

Strada Intrarea Panduri 4, Rudeni 077046,
Romania

Mob. : [+40] 721 297 342

E-mail: acrow.romania@acrow.co

KUWAIT

Al Aridiyah , Block 2 , Building 92,
Kuwait Khalid Ali Al Kharafi &
Bros.Co.W.LL

Tel.: [+965] 22083000 – Ext [240]

Fax: [+965] 22083001

E-mail: acrowkuwait@acrow.co

BAHRAIN

Acrow Bahrain Co. W.L.L

Office 1718, building 1260, Road 2421
Block 324 , Juffair, Manama , Kingdom of Bahrain

Mob. : [+973] 35 176 860

E-mail: acrowbahrain@acrow.co

QATAR

Acrow Qatar

Salwa Road, Red Tag building,
1st floor, Doha

P.O. Box No.: 15104

Tel.: [+974] 44582357

Fax: [+974] 44582376

E-mail: acrowqatar@acrow.co

OMAN

Acrow LLC

Office 23, Bin Hayl 2 Building , Bawshar
St ,Muscat , Sultanate of Oman

Tel. : [+968] 24 112 791

Mob. : [+968] 92 543 734

E-mail: acrowmuscat@acrow.co

JORDAN

Jordan - Amman - Al Jandawil - Hosni
Subar Str - Building no 05 - Third Floor

Mob. : [+962] 797 603 936

E-mail: acrow.jordan@acrow.co